

# Chapter 6

## The Link Layer and LANs

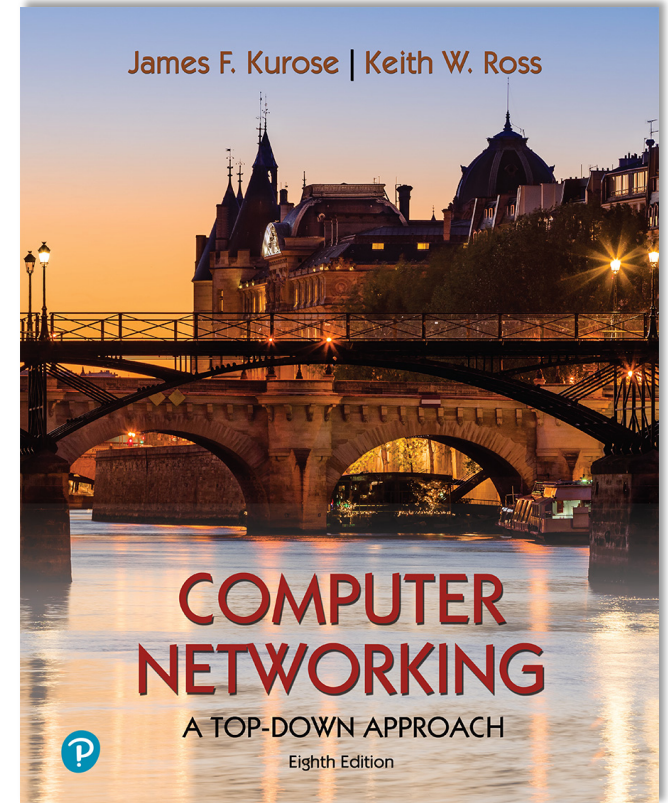

### *Computer Networking: A Top-Down Approach*

8<sup>th</sup> edition

Jim Kurose, Keith Ross  
Pearson, 2020

Acknowledgement: Based on the textbook's website:  
[https://gaia.cs.umass.edu/kurose\\_ross/index.php](https://gaia.cs.umass.edu/kurose_ross/index.php)

# Link layer and LANs: our goals

- understand principles behind link layer services:
  - error detection, correction
  - sharing a broadcast channel: multiple access
  - link layer addressing
  - local area networks: Ethernet, VLANs
- datacenter networks
- instantiation, implementation of various link layer technologies



# Link layer, LANs: roadmap

- **introduction**
- error detection, correction
- multiple access protocols
- LANs
  - addressing, ARP
  - Ethernet
  - switches
  - VLANs
- link virtualization: MPLS
- data center networking



- a day in the life of a web request

# Link layer: introduction

terminology:

- hosts, routers: **nodes**
- communication channels that connect **adjacent** nodes along communication path: **links**
  - wired , wireless
  - LANs
- layer-2 packet: **frame**, encapsulates datagram

*link layer* has responsibility of transferring datagram from one node to **physically adjacent** node over a link

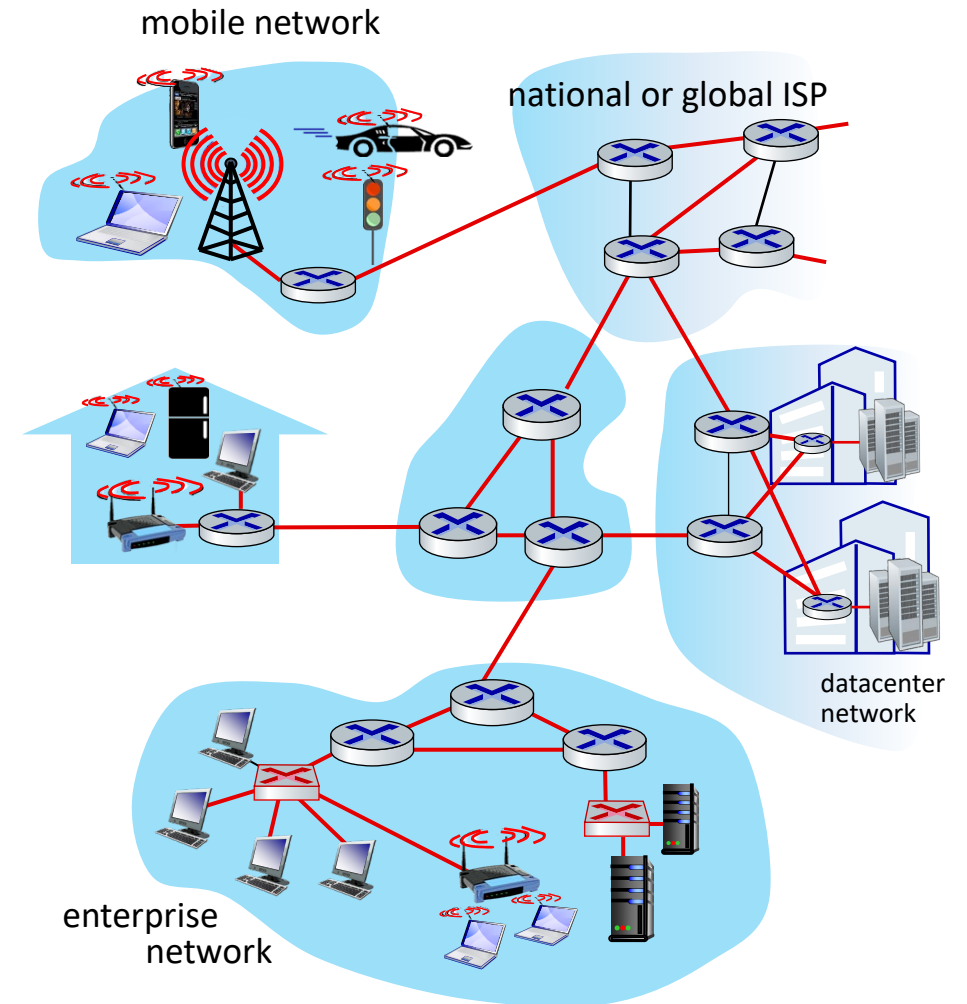

# Link layer: context

- datagram transferred by **different link protocols** over different links:
  - e.g., WiFi on first link, Ethernet on next link
- each link protocol provides different services
  - e.g., **may or may not** provide reliable data transfer over link

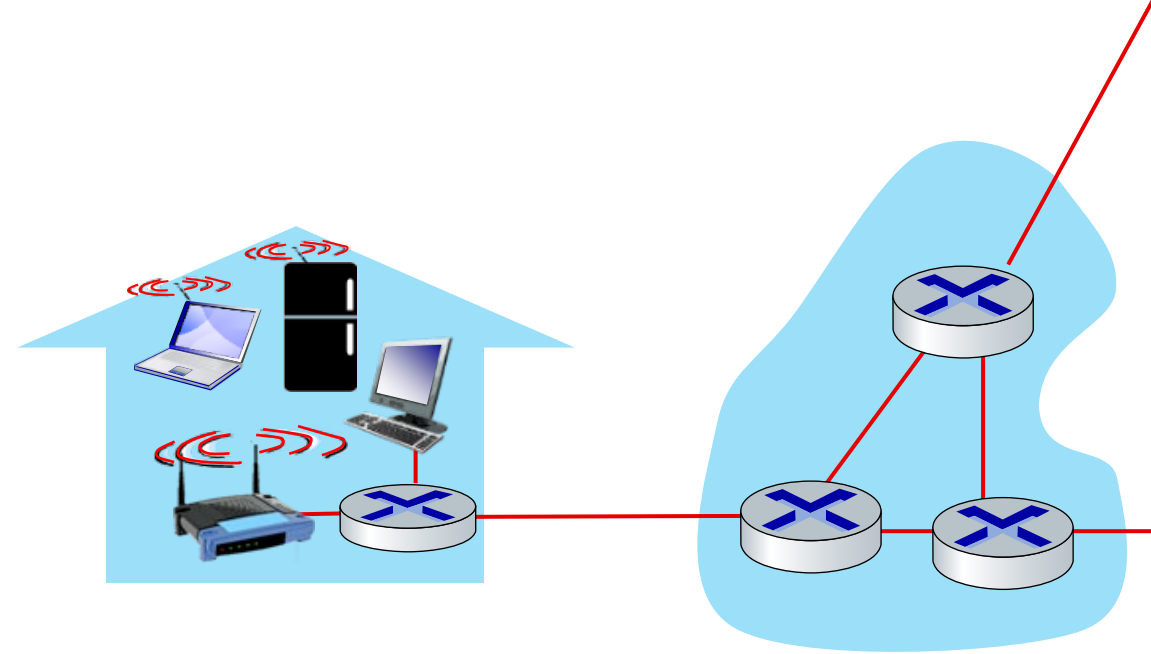

# Transportation analogy

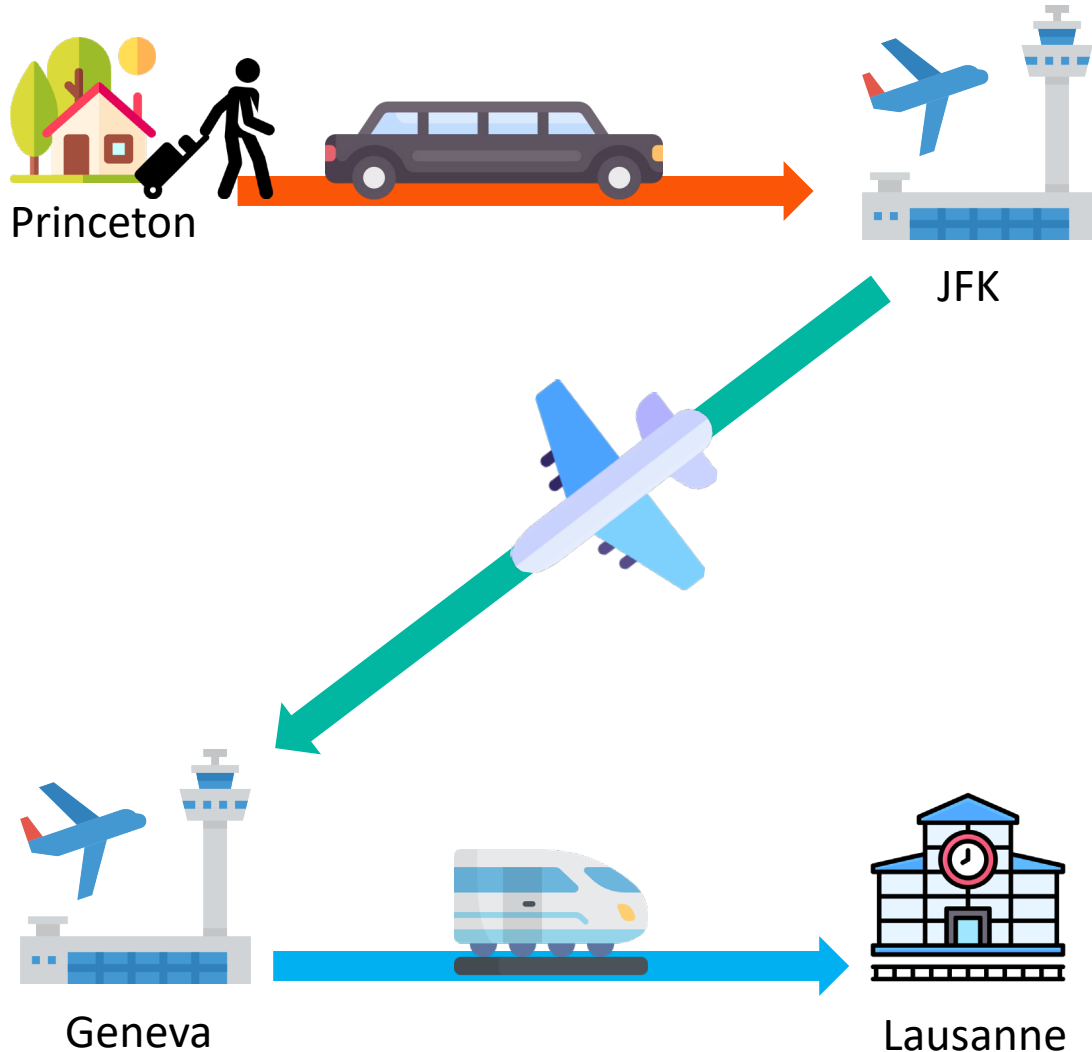

## transportation analogy:

- trip from Princeton to Lausanne
  - limo: Princeton to JFK
  - plane: JFK to Geneva
  - train: Geneva to Lausanne
- tourist = datagram
- transport segment = communication link
- transportation mode = link-layer protocol
- travel agent = routing algorithm

# Link layer: services

## ■ framing, link access:

- encapsulate datagram into frame, adding header, trailer
- channel access if shared medium
- “MAC” addresses in frame headers identify source, destination (different from IP address!)

## ■ reliable delivery between adjacent nodes

- we already know how to do this, i.e., higher-level end-end reliability protocols, e.g., TCP retransmissions.
  - seldom used on low bit-error links
- wireless links: high error rates
  - Q: why both link-level and end-end reliability?
  - A: link-level error detection reduces burden of higher-level end-end reliability protocols.

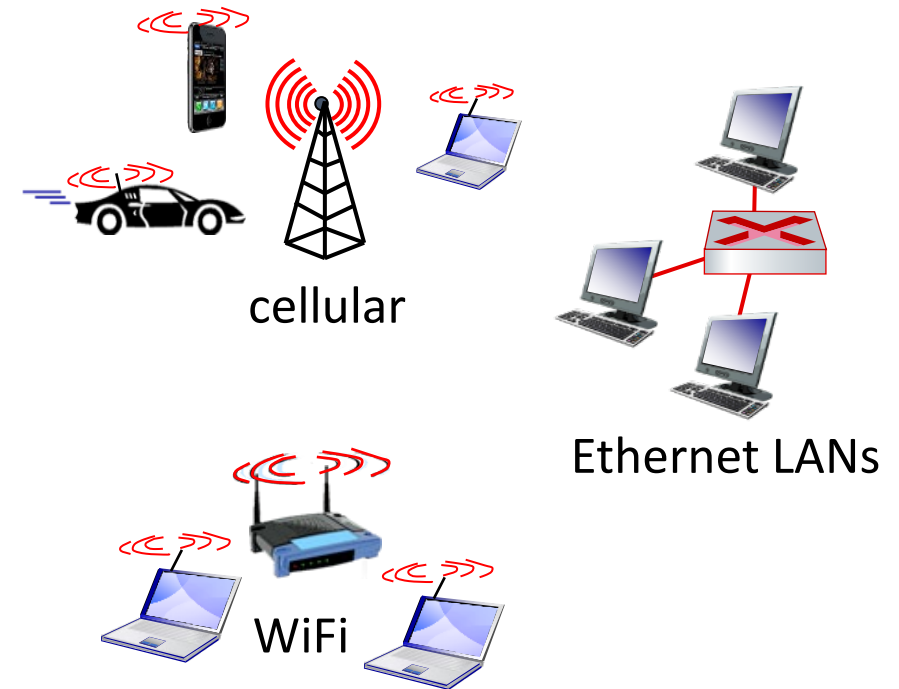
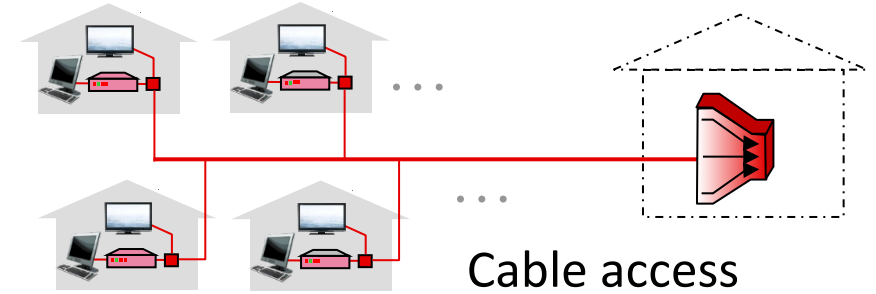

# Link layer: services (more)

- **flow control:**

- pacing between adjacent sending and receiving nodes

- **error detection:**

- errors caused by signal attenuation, noise.
- receiver detects errors, signals retransmission, or drops frame

- **error correction:**

- receiver identifies *and corrects* bit error(s) without retransmission

- **half-duplex and full-duplex:**

- with half duplex, nodes at both ends of link can transmit, but not at same time

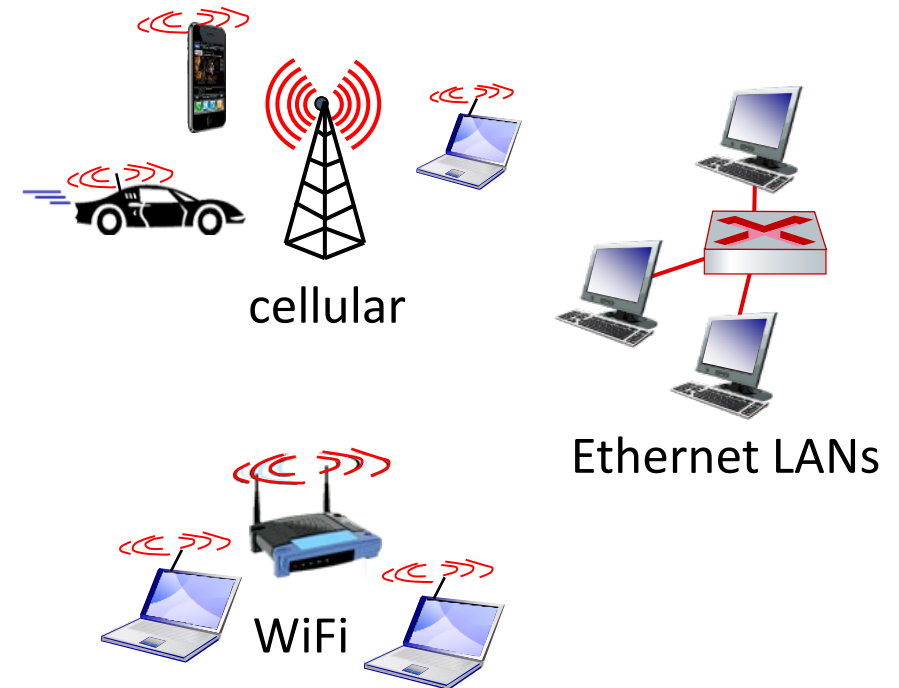
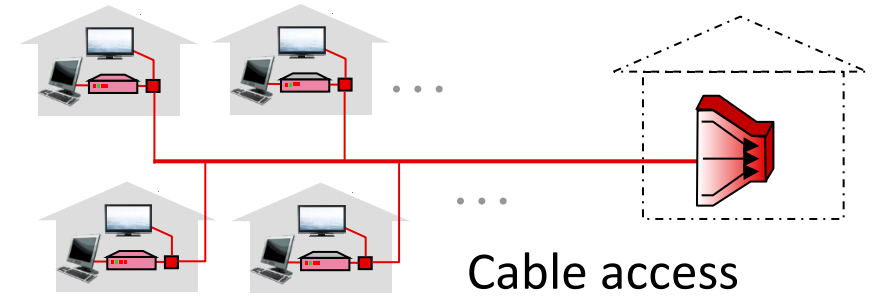



# Host link-layer implementation

- in each-and-every host
- link layer implemented on-chip or in network interface card (NIC)
  - implements link, physical layer
- attaches into host's system buses
- combination of hardware, software, firmware

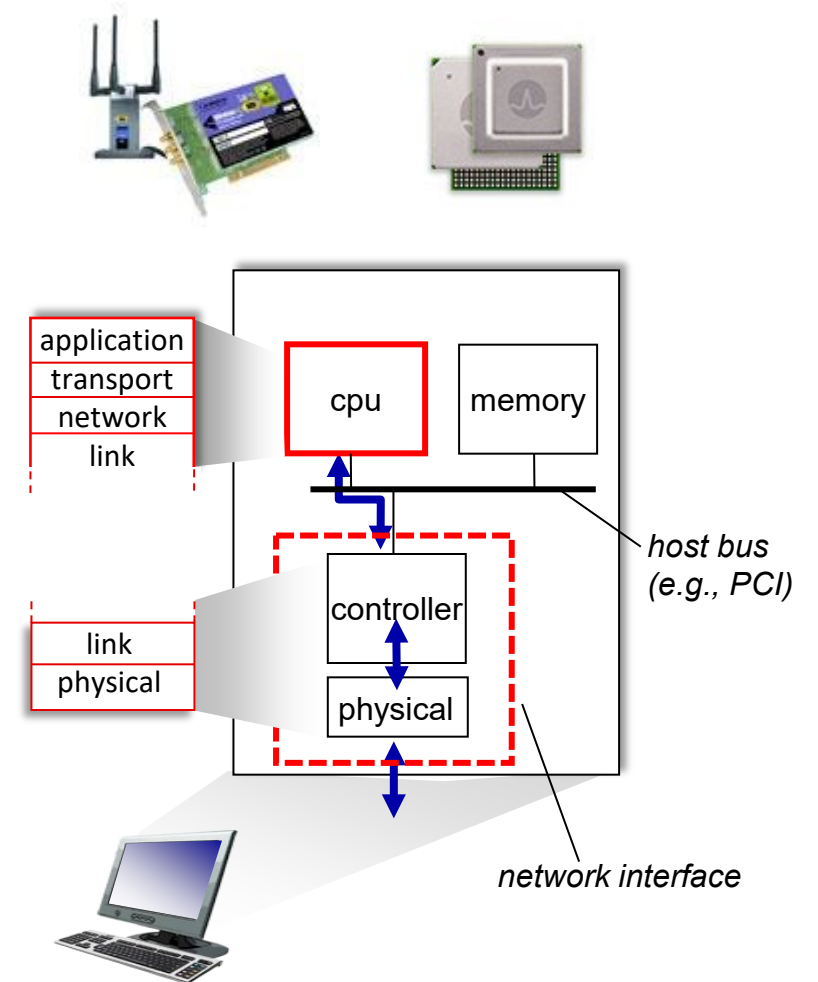

# Interfaces communicating

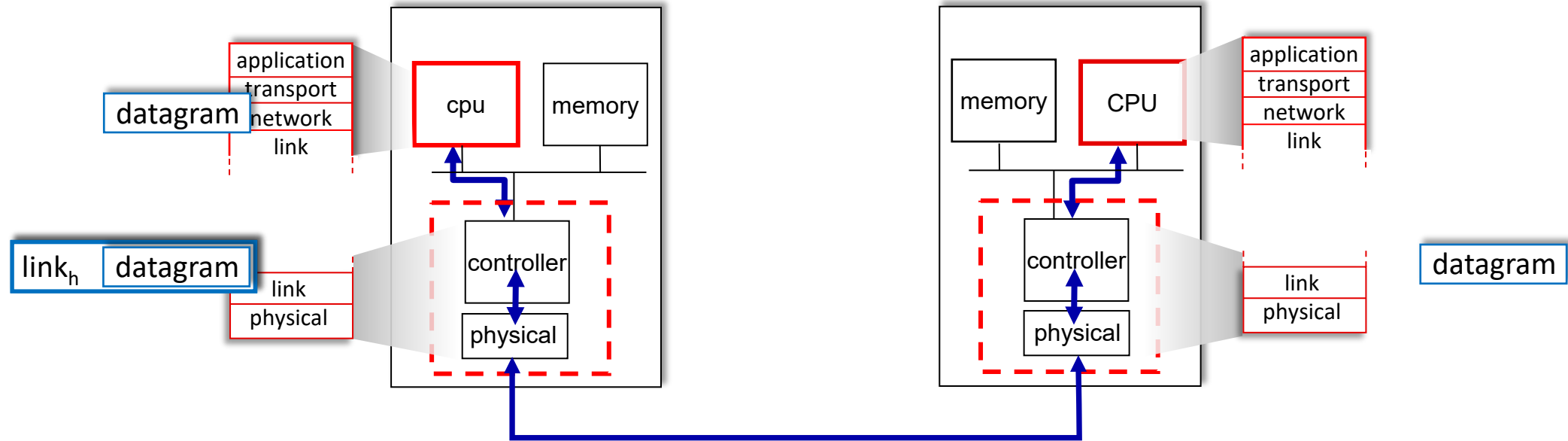

sending side:

- encapsulates datagram in frame
- adds error checking bits, reliable data transfer, flow control, etc.

receiving side:

- looks for errors, reliable data transfer, flow control, etc.
- extracts datagram, passes to upper layer at receiving side

# Link layer, LANs: roadmap

- introduction
- **error detection, correction**
- multiple access protocols
- LANs
  - addressing, ARP
  - Ethernet
  - switches
  - VLANs
- link virtualization: MPLS
- data center networking



- a day in the life of a web request

# Error detection

EDC: error detection and correction bits (e.g., redundancy)

D: data protected by error checking, may include header fields

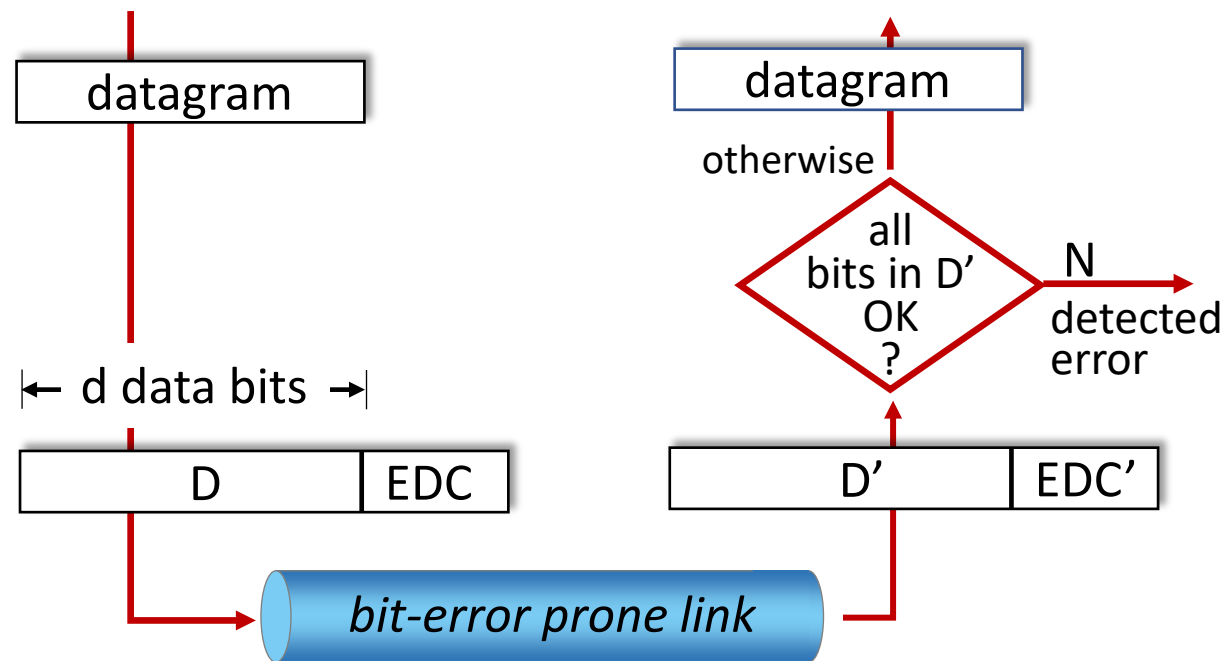

Error detection not 100% reliable!

- protocol may miss some errors, but rarely
- larger EDC field yields better detection and correction

# Parity checking: one-dimensional

## single parity bit for $d$ data bits:

- We consider even parity in this lecture
  - Even parity: set parity bit to 0 (1) if there is an even (odd) number of 1's, so the total # 1's is even.
  - Odd parity: set parity bit to 0 (1) if there is an odd (even) number of 1's, so the total # 1's is odd.

## At receiver:

- compute parity of  $d$  received bits
- compare with received parity bit – if different than error detected
- Can detect odd number of bit errors (1,3...) but not even number of bit errors (2,4...), which do not affect parity bit
  - e.g., error of 1 bit causes the parity bit to flip, but error of 2 bits does not
  - The vast majority of errors are single bit flips

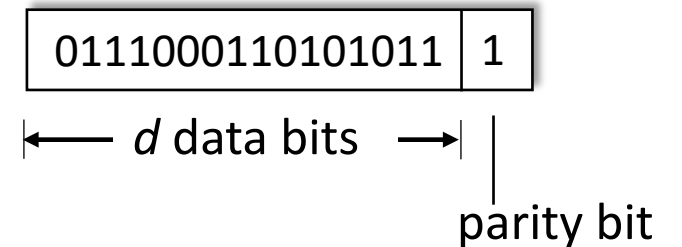

# Parity checking: two-dimensional

multiple parity bits for a two-dimensional array of data bits:

- Transmit data as a block of  $i$  rows of  $j$  bits per row and add parity bit to each row and each column.
- For  $i$  rows and  $j$  columns, compute  $j$  column parity bits (last row),  $i$  row bits (last column), and one corner parity bit computed by the row and column parity bits.
- All rows are concatenated and sent out. For the example, the following bits are sent:
  - 1 0 1 0 1 1 1 1 1 0 0 0 1 1 1 0 1 0 0 1 0 1 0
- Can detect and correct single-bit errors (without retransmission at the TCP layer)
  - But may (or may not) detect, and cannot correct, multiple bit errors

At receiver:

- compute the row, column and corner parity bits, and compare with received parity bits
  - If sum of # row parity errors and # column parity errors is odd, then the corner parity bit also has an error; if even, then the corner parity bit has no error
- For the example, receiver detects 2 parity errors, hence the erroneous data bit can be identified by the row and column numbers of the parity errors:
- Received: 1 0 1 0 1 1 1 0 1 1 0 0 0 1 1 1 0 1 0 0 1 0 1 0
- Computed: 1 0 1 0 1 1 1 0 1 1 0 1 0 1 1 1 0 1 0 1 1 0 1 0

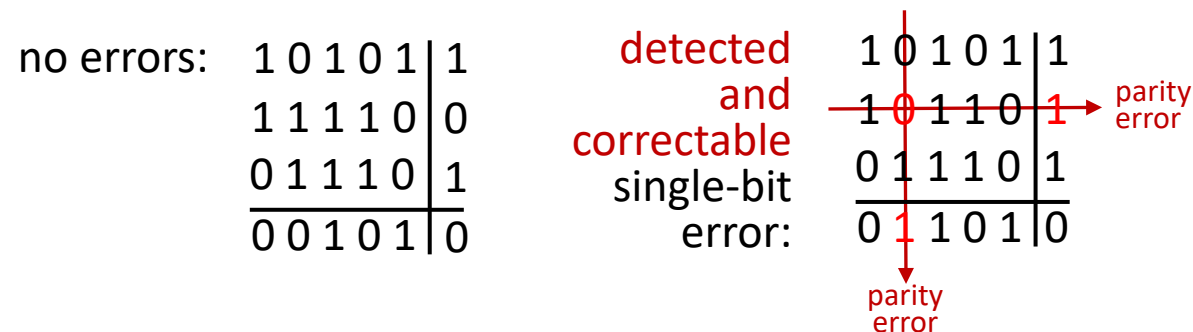
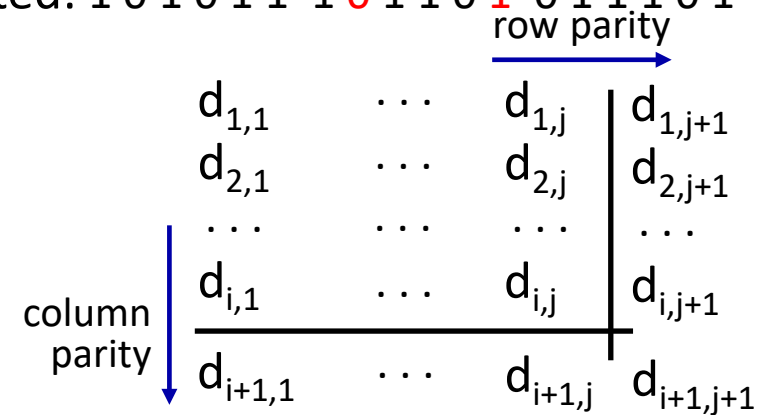

# Quiz: Number of Parity Errors

no errors: 
$$\begin{array}{cccc|c} 1 & 0 & 1 & 0 & 1 & 1 \\ 1 & 1 & 1 & 1 & 0 & 0 \\ 0 & 1 & 1 & 1 & 0 & 1 \\ \hline 0 & 0 & 1 & 0 & 1 & 0 \end{array}$$

$$\begin{array}{cccc|c} 1 & 0 & 1 & 0 & 1 & 1 \\ \hline 1 & 0 & 1 & 1 & 0 & 1 \\ \hline 0 & 1 & 1 & 1 & 0 & 1 \\ \hline 0 & 1 & 1 & 0 & 1 & 0 \end{array}$$

parity error (row 2)

parity error (column 2)

1-bit error causes 1 row parity error, 1 column parity error

$$\begin{array}{cccc|c} 1 & 0 & 1 & 0 & 1 & 1 \\ \hline 1 & 0 & 1 & 1 & 1 & 0 \\ \hline 0 & 1 & 1 & 1 & 0 & 1 \\ \hline 0 & 1 & 1 & 0 & 0 & 0 \end{array}$$

parity error (row 2)

parity error (column 4)

2-bit error causes 2 row parity errors

$$\begin{array}{cccc|c} 1 & 0 & 1 & 0 & 0 & 0 \\ \hline 1 & 0 & 1 & 1 & 0 & 1 \\ \hline 0 & 1 & 1 & 1 & 1 & 0 \\ \hline 0 & 1 & 1 & 0 & 1 & 0 \end{array}$$

parity error (row 1)

parity error (row 2)

parity error (row 3)

parity error (column 2)

3-bit error causes 3 row parity errors, 1 column parity error, 0 corner parity errors

$$\begin{array}{cccc|c} 1 & 1 & 1 & 0 & 0 & 1 \\ 1 & 1 & 1 & 1 & 0 & 0 \\ 0 & 0 & 1 & 1 & 1 & 1 \\ \hline 0 & 0 & 1 & 0 & 1 & 0 \end{array}$$

4-bit error causes NO parity error, hence cannot be detected

$$\begin{array}{cccc|c} 1 & 0 & 1 & \times & 1 & 1 \\ 1 & \times & 1 & 1 & 0 & 0 \\ 0 & 1 & 1 & 1 & 0 & 1 \\ \hline 0 & 0 & 1 & 0 & 1 & 0 \end{array}$$

2-bit error causes 2 row parity errors, 2 column parity errors, 0 corner parity errors

$$\begin{array}{cccc|c} 1 & 0 & 1 & \times & 1 & 1 \\ 1 & \times & 1 & 1 & 0 & 0 \\ 0 & 1 & \times & 1 & 0 & 1 \\ \hline 0 & 0 & 1 & 0 & 1 & 0 \end{array}$$

3-bit error causes 3 row parity errors, 3 column parity errors, 0 corner parity errors

$$\begin{array}{cccc|c} 1 & 0 & 1 & \times & 1 & 1 \\ 1 & \times & 1 & 1 & 0 & 0 \\ 0 & 1 & \times & 1 & \times & 1 \\ \hline 0 & 0 & 1 & 0 & 1 & 0 \end{array}$$

4-bit error causes 2 row parity errors, 4 column parity errors, 0 corner parity errors

# Internet checksum (review, see section 3.3)

*Goal:* detect errors (*i.e.*, flipped bits) in transmitted segment

## sender:

- treat contents of UDP segment (including UDP header fields and IP addresses) as sequence of N-bit integers, where N may be 4, 8, 16...
- **checksum:** addition (one's complement sum) of the sequence of integers
  - One's complement sum is defined as sum modulo  $2^N$ , and adding any overflow of high order bits back into low-order bits, then taking one's complement (invert all bits)
- checksum value put into UDP checksum field

## receiver:

- compute checksum of received segment
- check if computed checksum equals checksum field value:
  - not equal - error detected
  - equal - no error detected. (*But maybe errors nonetheless*)



# Internet checksum: an example

One's complement sum for 16-bit integers is defined as sum modulo  $2^N$ ,  $N=16$ , and adding any overflow of high order bits back into low-order bits, then taking one's complement

		1	1	1	0	0	1	1	0	0	1	1	0	0	1	1	0
		1	1	0	1	0	1	0	1	0	1	0	1	0	1	0	1
		<hr/>															
wraparound	1	1	0	1	1	1	0	1	1	1	0	1	1	1	0	1	1
		<hr/>															
sum		1	0	1	1	1	0	1	1	1	0	1	1	1	1	0	0
checksum		0	1	0	0	0	1	0	0	0	1	0	0	0	0	1	1

*Note:* when adding numbers, a carryout from the most significant bit needs to be added to the result

\* Check out the online interactive exercises for more examples: [http://gaia.cs.umass.edu/kurose\\_ross/interactive/](http://gaia.cs.umass.edu/kurose_ross/interactive/)

# Internet checksum: weak protection!

example: add two 16-bit integers

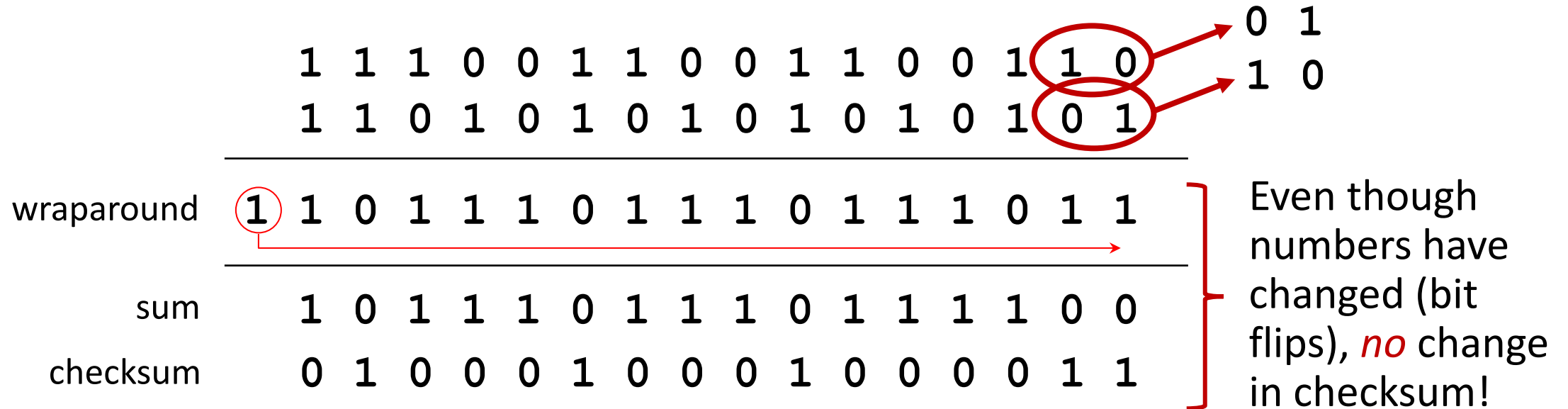

# Example in Decimal Number

□ Make a number divisible by 9

▪ **Example:** 823 is to be sent

1. Left-shift: 8230

2. Divide by 9, find remainder: 4

3. Subtract remainder from 9:  $9-4=5$

4. Add the result of step 3 to step 1: 8235

5. Check that the received result is divisible by 9. If not, then has error

▪ Detects all single-digit errors: 7235, 8335, 8255, 8237

▪ Detects several multiple-digit errors: 8765, 7346, 7335, 8775, ...

▪ Does not detect transpositions: 2835

# Cyclic Redundancy Check (CRC)

- more powerful error-detection coding based on modulo 2 arithmetic
- **D**: data bits (given, think of these as a binary number)
- **G**: bit pattern (generator), of  $r+1$  bits (given, specified in CRC standard)



- sender*: compute  $r$  CRC bits, **R**, such that  $\langle D, R \rangle$  *exactly* divisible by  $G \pmod{2}$
- receiver knows  $G$ , divides  $\langle D, R \rangle$  by  $G$ . If non-zero remainder: error detected!
  - can detect all burst errors less than  $r+1$  bits
  - widely used in practice (Ethernet, 802.11 WiFi)

# Exclusive OR (XOR) for Modulo 2 Arithmetic

- $0 \text{ XOR } 0 = 0$  (Same Bits)
  - $1 \text{ XOR } 1 = 0$  (Same Bits)
  - $1 \text{ XOR } 0 = 1$  (Different Bits)
  - $0 \text{ XOR } 1 = 1$  (Different Bits)
- With XOR arithmetic, addition + and subtraction - operations are the same
    - $1111 + 1010$
    - $= 1111 - 1010$
    - $= 1111 \text{ XOR } 1010$
    - $= 0101$

# Modulo 2 Addition, Multiplication

## Addition:

1-bit				2-bit				3-bit
1	0	0	1	00	01	10	11	110
<u>+1</u>	<u>+0</u>	<u>+1</u>	<u>+0</u>	<u>+11</u>	<u>+11</u>	<u>+11</u>	<u>+11</u>	<u>+101</u>
0	0	1	1	11	10	01	00	011

## Multiplication:

1-bit				2-bit			
1	0	0	1	00	01	10	11
<u>×1</u>	<u>×0</u>	<u>×1</u>	<u>×0</u>	<u>×11</u>	<u>×11</u>	<u>×11</u>	<u>×11</u>
1	0	0	0	00	01	10	11
				<u>00</u>	<u>01</u>	<u>10</u>	<u>11</u>
				000	011	110	101

# Modulo 2 Division

$$\begin{array}{r} 116 \\ 13 \overline{) 1514} \\ \underline{13} \phantom{00} \\ 21 \phantom{00} \\ \underline{13} \phantom{00} \\ 84 \\ \underline{78} \\ 6 \end{array}$$

$$\begin{array}{r} 110 \\ 10 \overline{) 1101} \\ \underline{10} \phantom{00} \\ 010 \\ \underline{10} \phantom{00} \\ 001 \\ \underline{00} \\ 01 \end{array}$$

$$\begin{array}{r} 1101 \\ 10 \overline{) 11011} \\ \underline{10} \phantom{000} \\ 010 \phantom{00} \\ \underline{10} \phantom{00} \\ 001 \phantom{00} \\ \underline{00} \phantom{00} \\ 011 \\ \underline{10} \\ 01 \end{array}$$

Decimal Arithmetic:

$$1514/13=116, \text{ remainder } 6$$

Mod-2 Arithmetic:

$$1101/10=110, \text{ remainder } 01$$

$$11011/10=1101, \text{ remainder } 01$$

# Cyclic Redundancy Check (CRC): Example 1

Sender wants to compute R  
such that for some integer  $n$ :

$$D \cdot 2^r \text{ XOR } R = nG$$

... or equivalently (XOR R both sides):

$$D \cdot 2^r = nG \text{ XOR } R$$

... which says:

if we divide  $D \cdot 2^r$  by  $G$ , we  
want remainder  $R$  to satisfy:

$$R = \text{remainder} \left[ \frac{D \cdot 2^r}{G} \right] \text{ algorithm for computing } R$$

Example:  $D=101110$ ,  $G=1001$ ,  $r=3$

$$D \cdot 2^r = 101110000 \rightarrow R=011$$

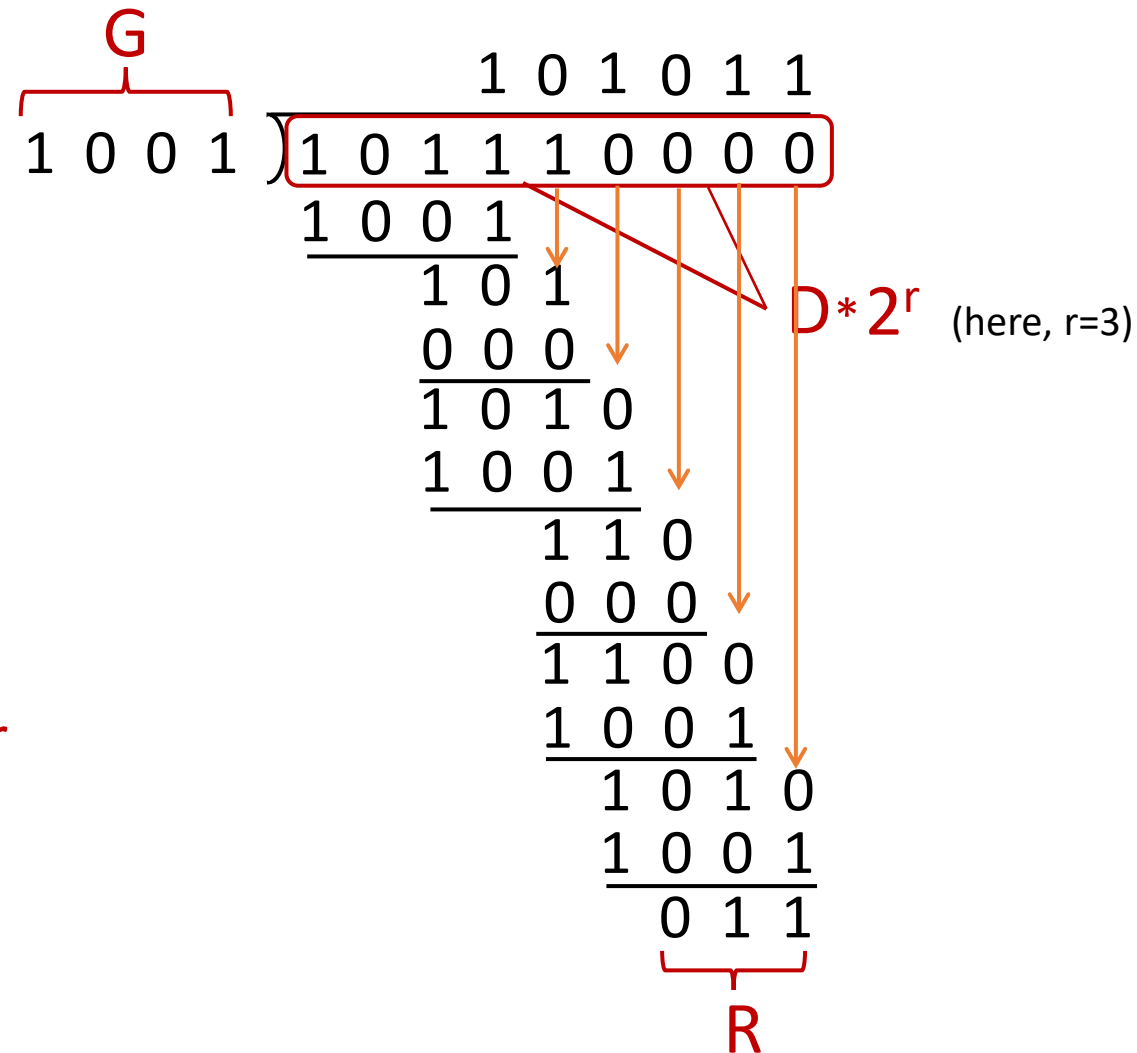

\* Check out the online interactive exercises for more examples: [http://gaia.cs.umass.edu/kurose\\_ross/interactive/](http://gaia.cs.umass.edu/kurose_ross/interactive/)



# Cyclic Redundancy Check (CRC): Example 1 Cont

- Add remainder to  $D \cdot 2^r$
- $D \cdot 2^r + R = D \cdot 2^r \text{ XOR } R$   
 $= 101110000 \text{ XOR } 011$   
 $= 101110011$

It must be divisible by  $G=1001$ ,  
 i.e. remainder of the division is 0,

$D \cdot 2^r + R$  is divisible by  $G$ , or

$$D \cdot 2^r \text{ XOR } R = nG$$

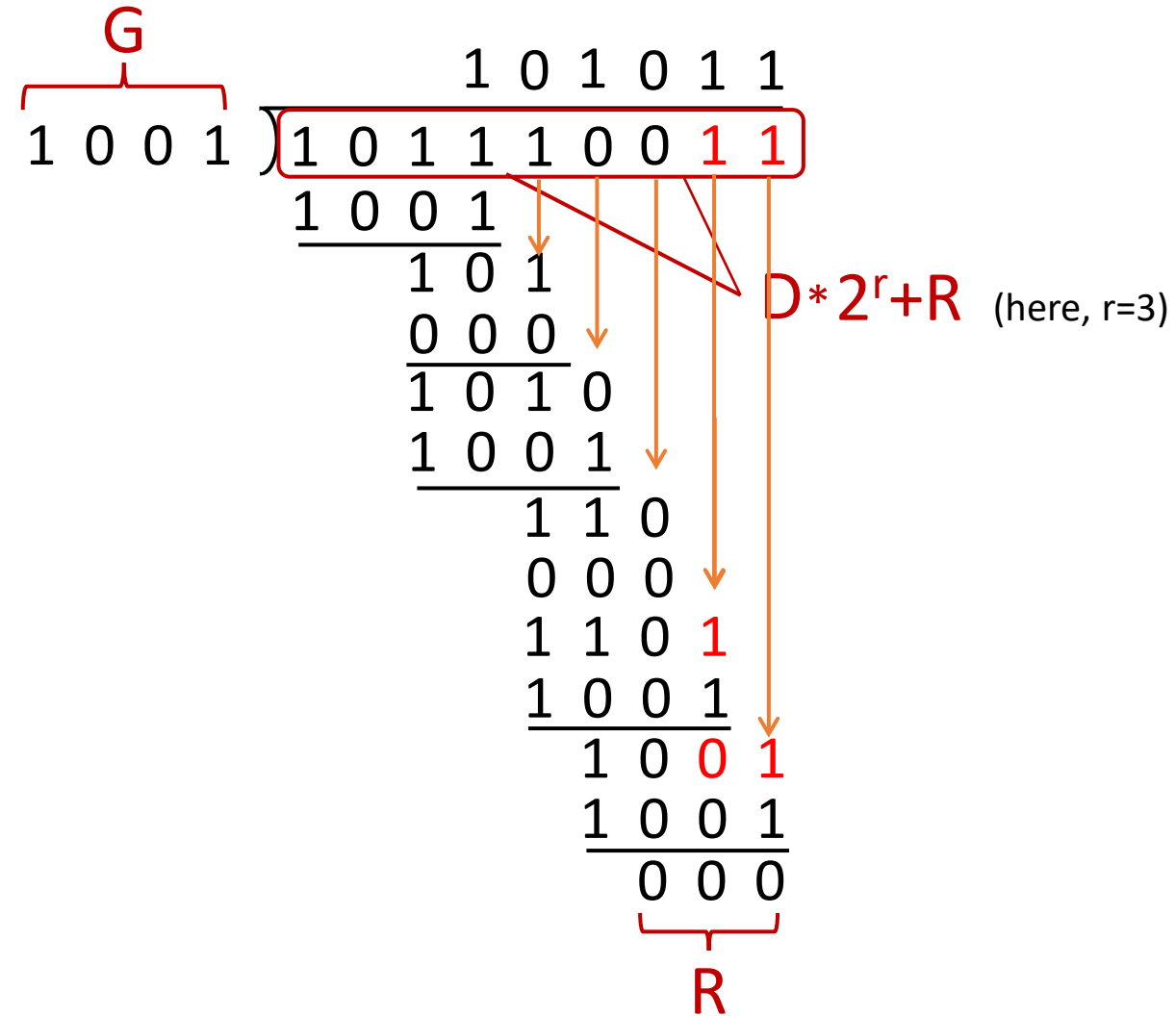

# Cyclic Redundancy Check (CRC): Example 2

Sender wants to compute R  
such that for some integer  $n$ :

$$D \cdot 2^r \text{ XOR } R = nG$$

... or equivalently (XOR R both sides):

$$D \cdot 2^r = nG \text{ XOR } R$$

... which says:

if we divide  $D \cdot 2^r$  by  $G$ , we  
want remainder  $R$  to satisfy:

$$R = \text{remainder} \left[ \frac{D \cdot 2^r}{G} \right] \text{ algorithm for computing } R$$

Example:  $D=100100$ ,  $G=1101$ ,  $r=3$   
 $D \cdot 2^r = 100100000$ ,  $R=001$

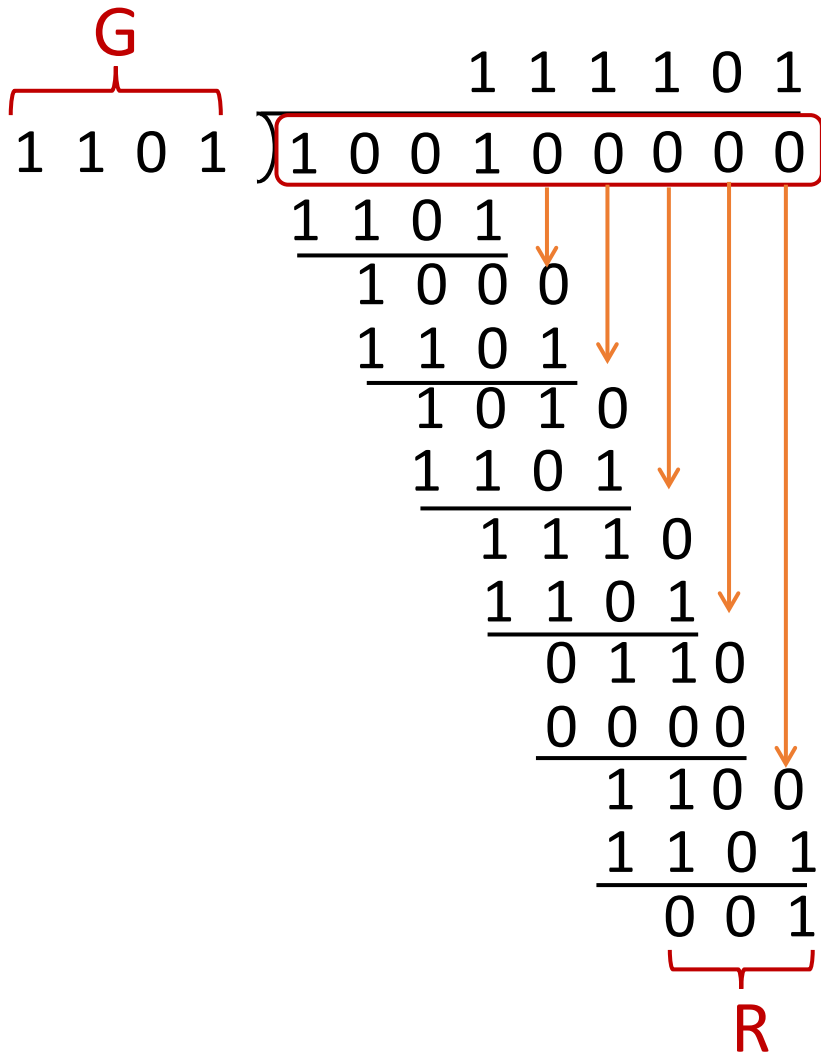

# Cyclic Redundancy Check (CRC): Example 2 Cont

- Add remainder to  $D \cdot 2^r$
- $D \cdot 2^r + R = D \cdot 2^r \text{ XOR } R$   
 $= 100100000 \text{ XOR } 001$   
 $= 100100001$

It must be divisible by  $G=1101$ ,  
 i.e. remainder of the division is 0,

$D \cdot 2^r R$  is divisible by  $G$ , or

$$D \cdot 2^r \text{ XOR } R = nG$$

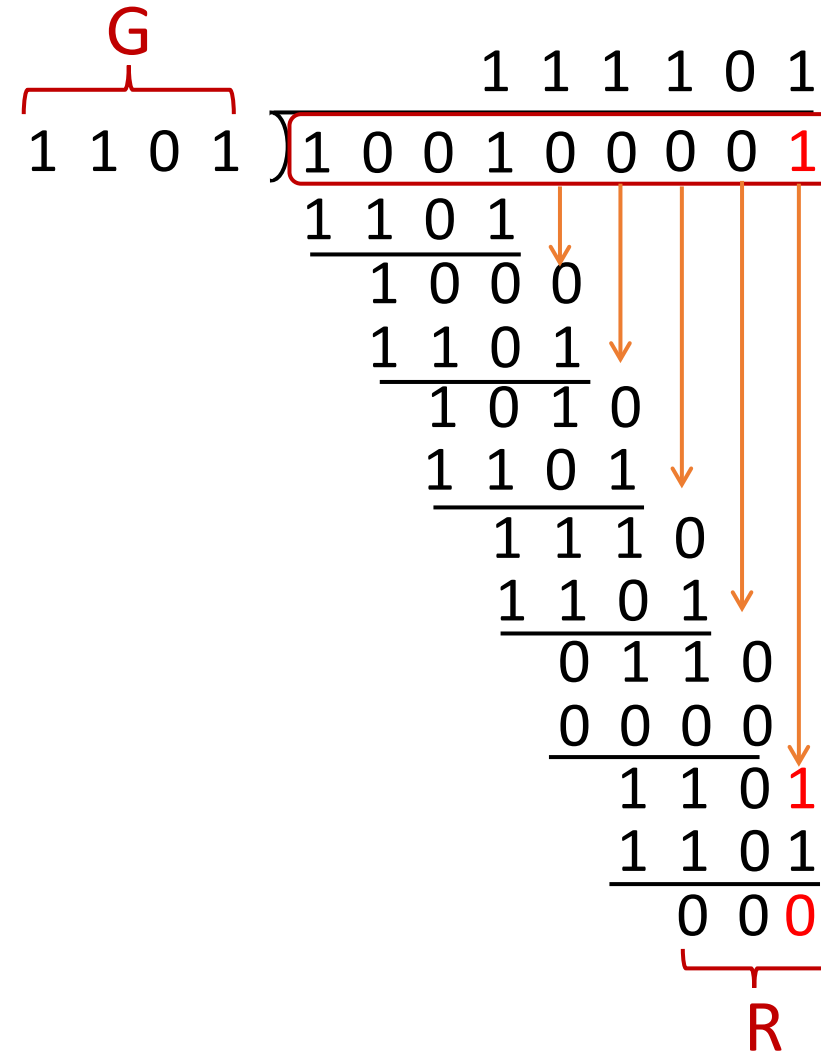

\* Check out the online interactive exercises for more examples: [http://gaia.cs.umass.edu/kurose\\_ross/interactive/](http://gaia.cs.umass.edu/kurose_ross/interactive/)

# Cyclic Redundancy Check (CRC): Example 3

Example 2:  $D=1011010010$ ,  
 $G=110010$ ,  $r=5$   
 $D \cdot 2^r = 1011010010000000$   
 $\rightarrow R=01000$

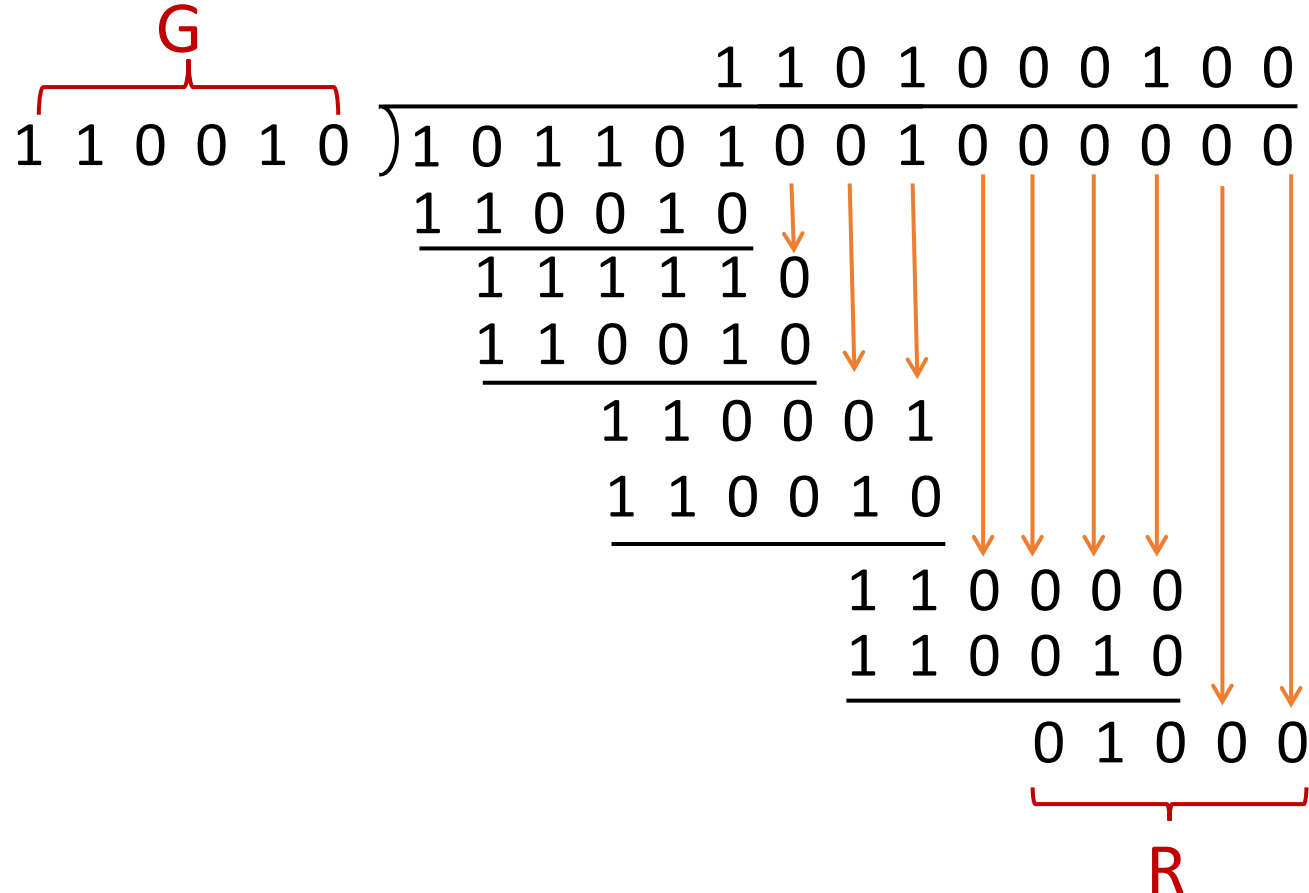

# Cyclic Redundancy Check (CRC): Example 3 Cont

- $D \cdot 2^r + R = D \cdot 2^r \text{ XOR } R$

$$= 101101001000000 \text{ XOR } 01000$$

$$= 101101001001000$$

It must be divisible by  $G = 110010$ ,  
i.e. remainder of the division is 0,

$D \cdot 2^r \text{ XOR } R$  is divisible by  $G$ , or

$$D \cdot 2^r \text{ XOR } R = nG$$

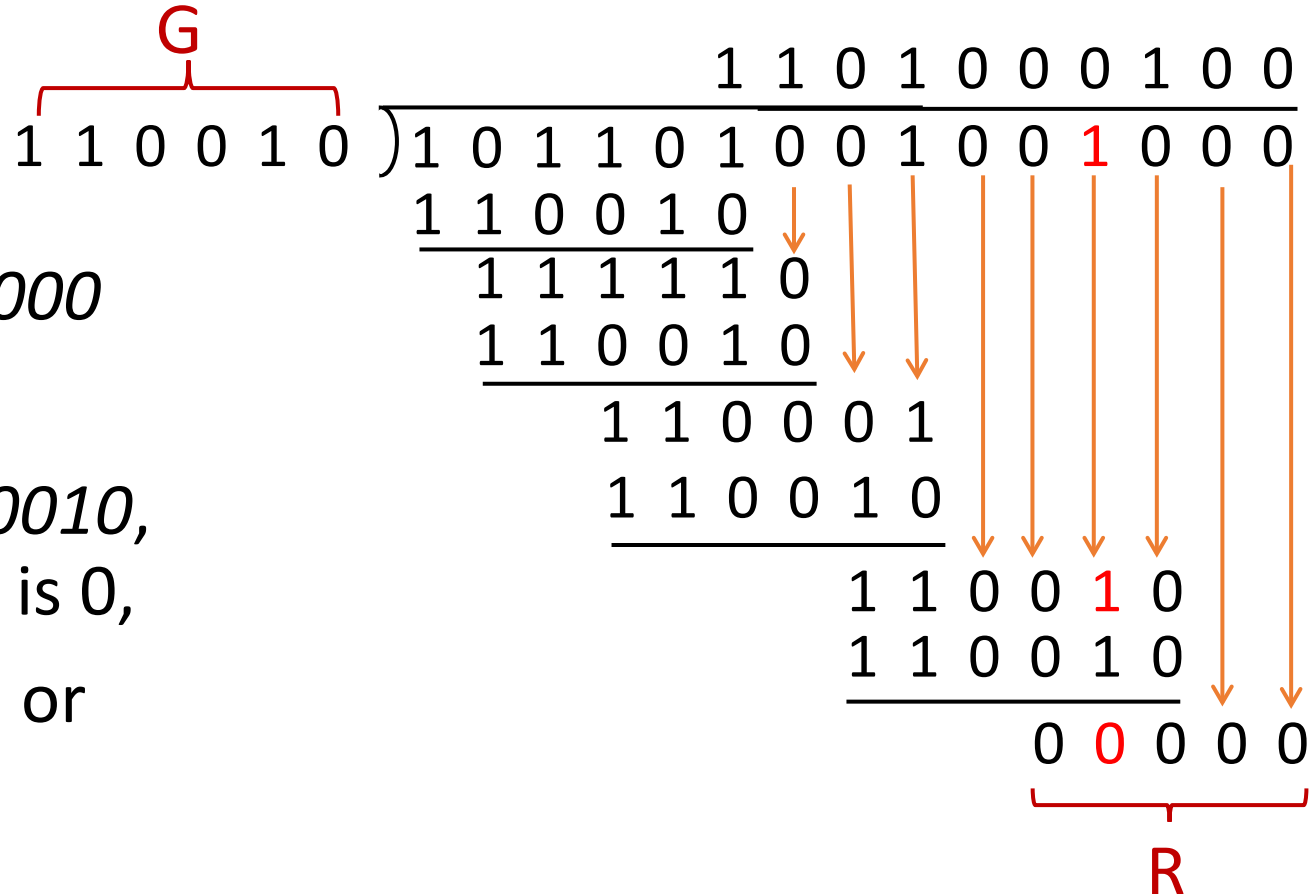

# Video Tutorials

- Error Detection
  - <https://www.youtube.com/watch?v=EMrY-8m8D1E&list=PLBlNk6fEyqRgMCUAG0XRw78UA8qnv6jEx&index=44>
- Vertical Redundancy Check (VRC)
  - <https://www.youtube.com/watch?v=UwERCzJv-y8&list=PLBlNk6fEyqRgMCUAG0XRw78UA8qnv6jEx&index=45>
- Longitudinal Redundancy Check (LRC)
  - <https://www.youtube.com/watch?v=nNONvBsOtrE&list=PLBlNk6fEyqRgMCUAG0XRw78UA8qnv6jEx&index=46>
- Checksum
  - <https://www.youtube.com/watch?v=AtVWnyDDaDI&list=PLBlNk6fEyqRgMCUAG0XRw78UA8qnv6jEx&index=47>
- Cyclic Redundancy Check (CRC) - Part 1 (This is [Example 2](#))
  - <https://www.youtube.com/watch?v=A9g6rTMblz4&list=PLBlNk6fEyqRgMCUAG0XRw78UA8qnv6jEx&index=48>
- Cyclic Redundancy Check (CRC) - Part 2 (This is [Example 2 Cont](#))
  - <https://www.youtube.com/watch?v=wQGwfBS3gpk&list=PLBlNk6fEyqRgMCUAG0XRw78UA8qnv6jEx&index=49>
- Cyclic Redundancy Check (Solved Problem)
  - <https://www.youtube.com/watch?v=tEkePtIujSA&list=PLBlNk6fEyqRgMCUAG0XRw78UA8qnv6jEx&index=50>
- Error Detection and Correction 2: Cyclic Redundancy Check (This is [Example 3](#))
  - <https://www.youtube.com/watch?v=6gbkoFciryA>

# Quiz 1 Parity Checking

- Q: Compute the parity bits for the following data matrix:

- 1 0 1
- 0 1 0
- 1 1 1

- A:

- 1 0 1 | 0
- 0 1 0 | 1
- 1 1 1 | 1
- -----
- 0 0 0 | 0

- Q: Compute the parity bits for the following data matrix:

- 1 0 1
- 0 0 0
- 1 0 1

- A:

- 1 0 1 | 0
- 0 0 0 | 0
- 1 0 1 | 0
- -----
- 0 0 0 | 0

# Quiz 2 Internet checksum

- Q: Suppose that a packet 1001 1100 1010 0011 is transmitted using Internet checksum (N=4-bit integer). What is the value of the checksum?
- A: One's complement sum for 4-bit integers is defined as sum modulo  $2^N$ ,  $N=4$ , and adding any overflow of high order bits back into low-order bits, then taking one's complement.
- $0011+1010 = 1101$
- $1101+1100 = 1001+1 = 1010$
- $1010+1001 = 0011+1 = 0100$ .
- So, the Internet checksum is 1011, the one's complement of 0100.
- You can also do it in one step as shown on the right.

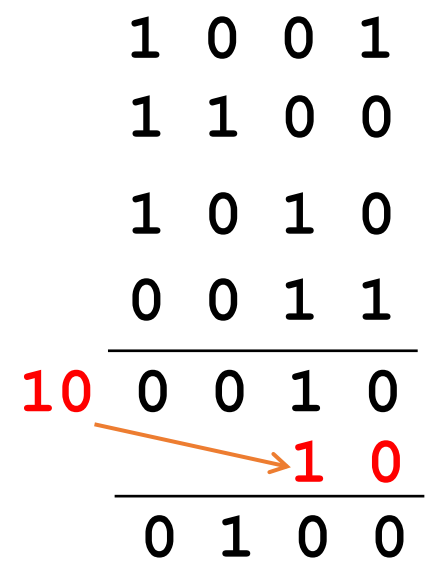



# Quiz 3 CRC

- Q: A bit stream 1001 is transmitted using the standard CRC method. The generator is 1011. Show the actual bit string transmitted. Suppose that the first bit sent is inverted during transmission error. Show that this error is detected at the receiver's end. Give an example of bit errors in the bit string transmitted that will not be detected by the receiver.
- A:  $D=1001$ ,  $G=1011$ ,  $r=3$ . Compute  $R$
- The message after appending three zeros is 1001000. The remainder on dividing 1001000 by 1011 is 110. So, the actual bits transmitted are 1001110.
- The received bit stream with an error in the first bit is 0001110. Dividing this by 1011 produces a remainder of 101, which is different from 0. Thus, the receiver detects an error.
- If the transmitted bit stream is converted to any multiple of 1001, the error will not be detected. A trivial example is if all ones in the bit stream are inverted to 0.

# Quiz 4 CRC

- $D=110011$ ,  $G=1001$ ,  $r=3$ .  
Compute  $R$

- $D=1001100$ ,  $G=1011$ ,  $r=3$ .  
Compute  $R$